

**NOTICE DE MONTAGE ET D'UTILISATION
ASSEMBLY AND USAGE INSTRUCTIONS**

**ERDE
-143.2**

**DAXARA by erde
-148.2**

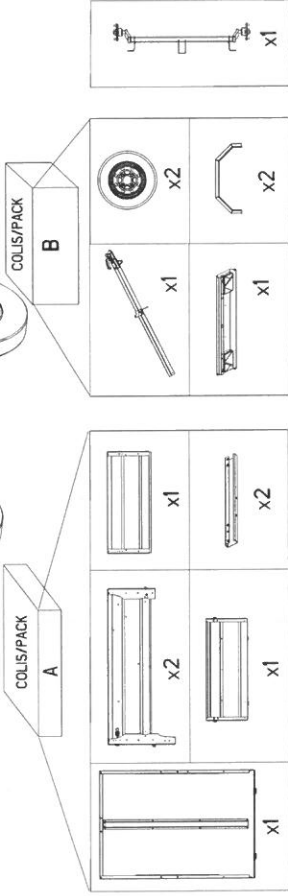
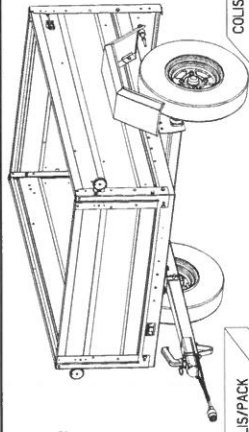

SACHET DE VIS COLIS B / NUTS AND BOLTS CONTENT PACK B

	x6	HM 10x25		x4	HM 8x25		x4	HM 8x50		x2	HM 6x12		x4		x4		x10
	x6	HM 10x25		x4	HM 8x25		x4	HM 8x50		x2	HM 6x12		x4		x4		x10
	x1	HM 10x90		x1	FR HM 10		x1	ETRIER/CLAMP		x1	BROCHE/PIN		x1				

BOULONNERIE MONTÉE SUR TIMON / NUTS AND BOLTS ASSEMBLED ON TILLER

BOULONNERIE MONTÉE SUR TIMON / NUTS AND BOLTS ASSEMBLED ON TILLER		VIS/BOLTS	
EQUIERRE/SQUARE/CATA/REFLECTOR	RIVET	VIS/BOLTS	

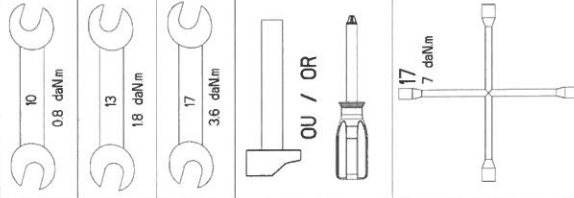

PORTER DES GANTS POUR LE MONTAGE
WEAR GLOVES FOR THE ASSEMBLY.

OUTILS NECESSAIRES POUR LE MONTAGE NON FOURNIS
NECESSARY TOOLS FOR ASSEMBLY NOT PROVIDED





A

NE PAS BLOQUER LES FIXATIONS DES OPERATIONS SUIVANTES
 NOT TO BLOCK FIXINGS OF THE FOLLOWING OPERATIONS

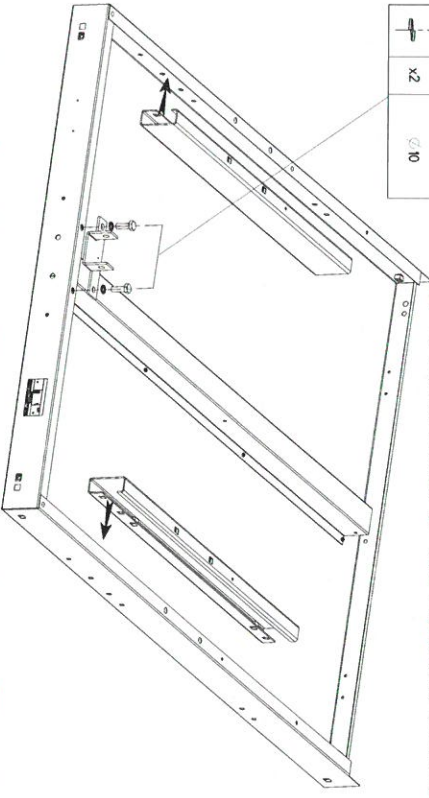
	x2	HM 10x25
	x2	Ø 10



B

	x4	HM 10x25
	x4	Ø 10
	x4	Ø 10

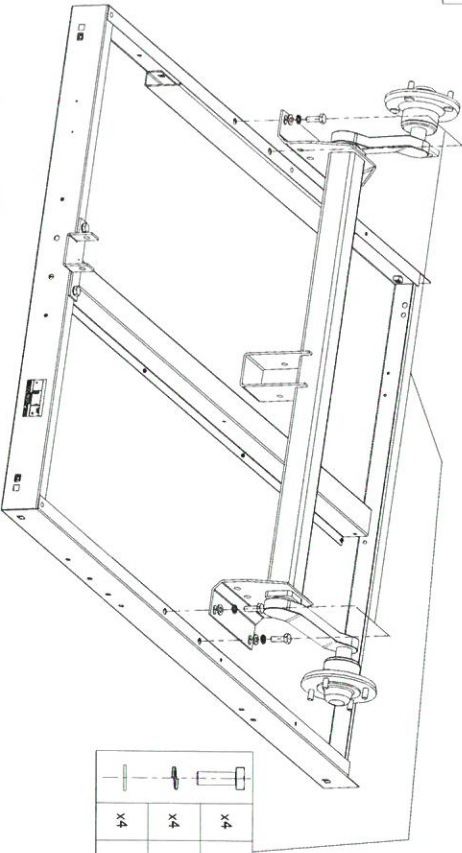

C

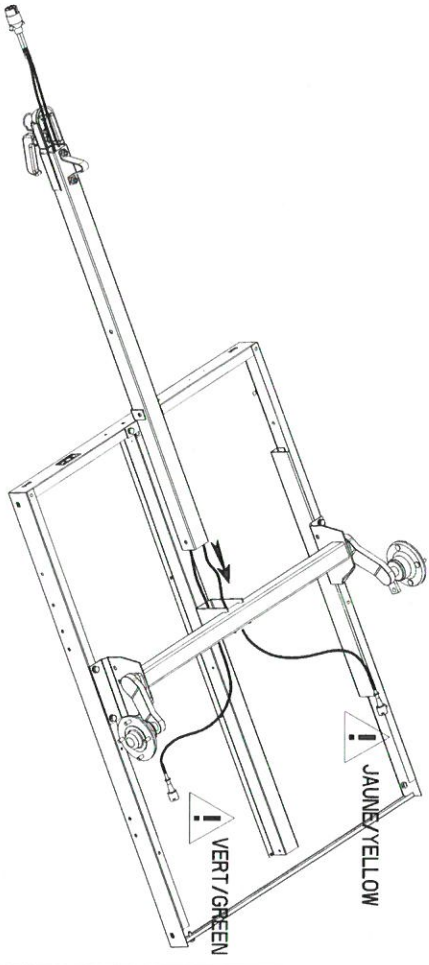

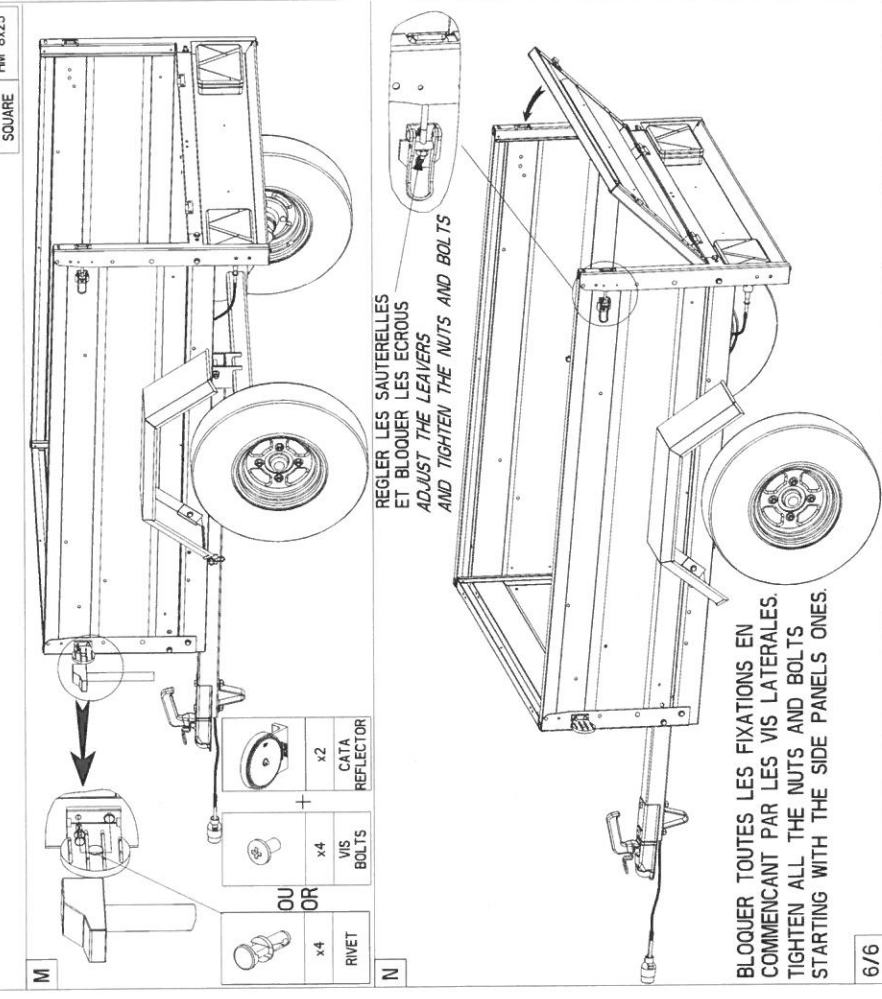
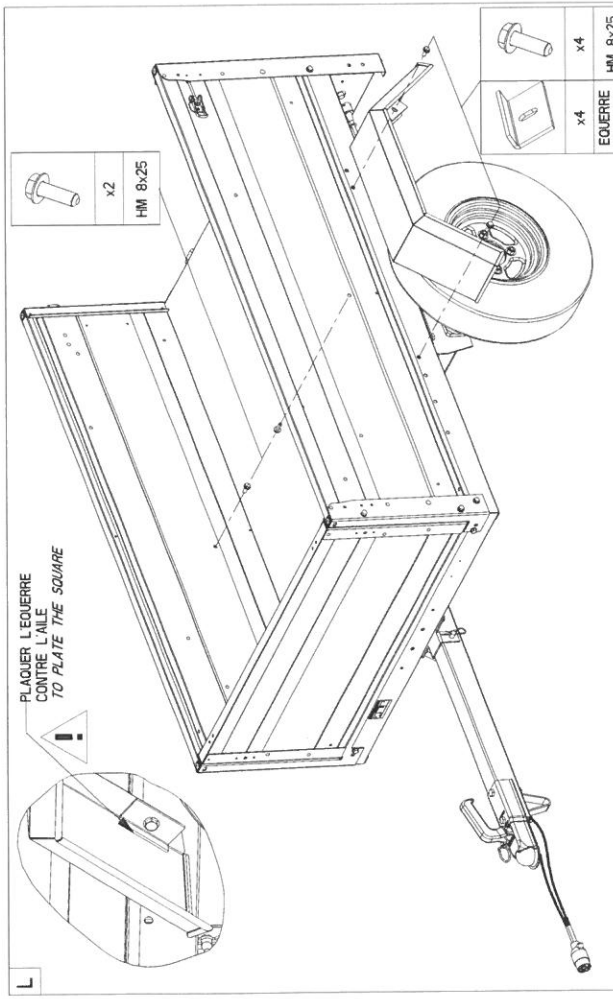
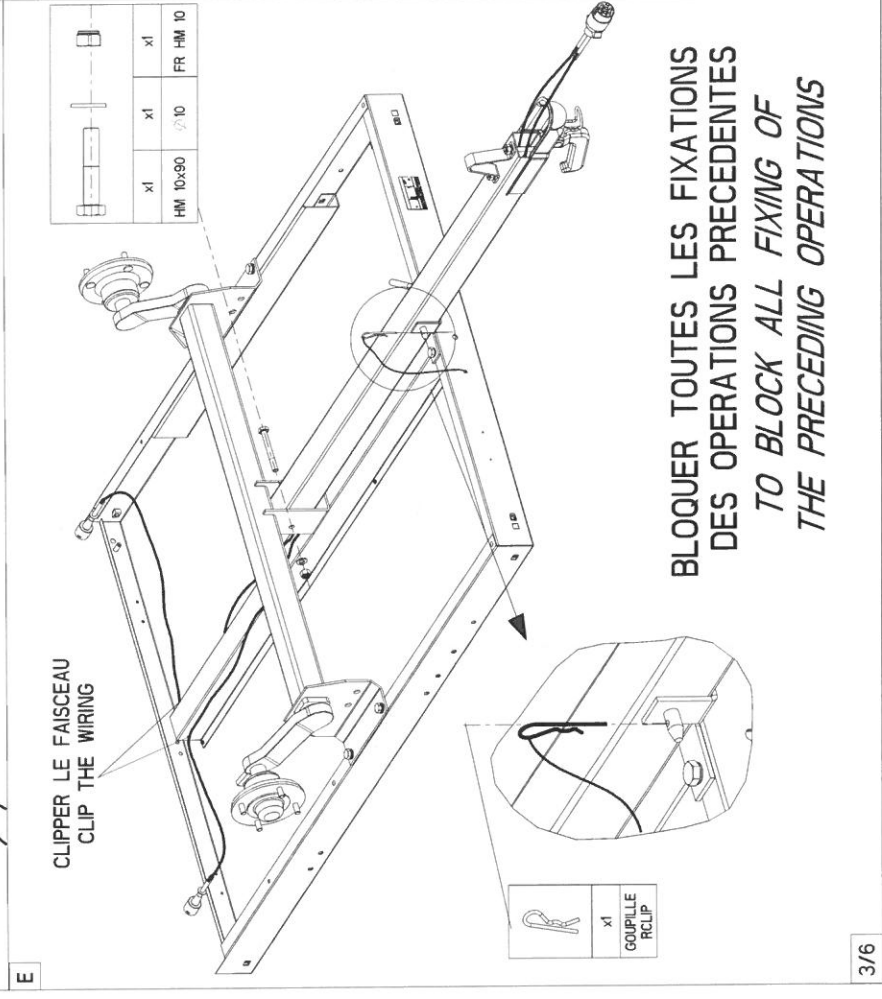
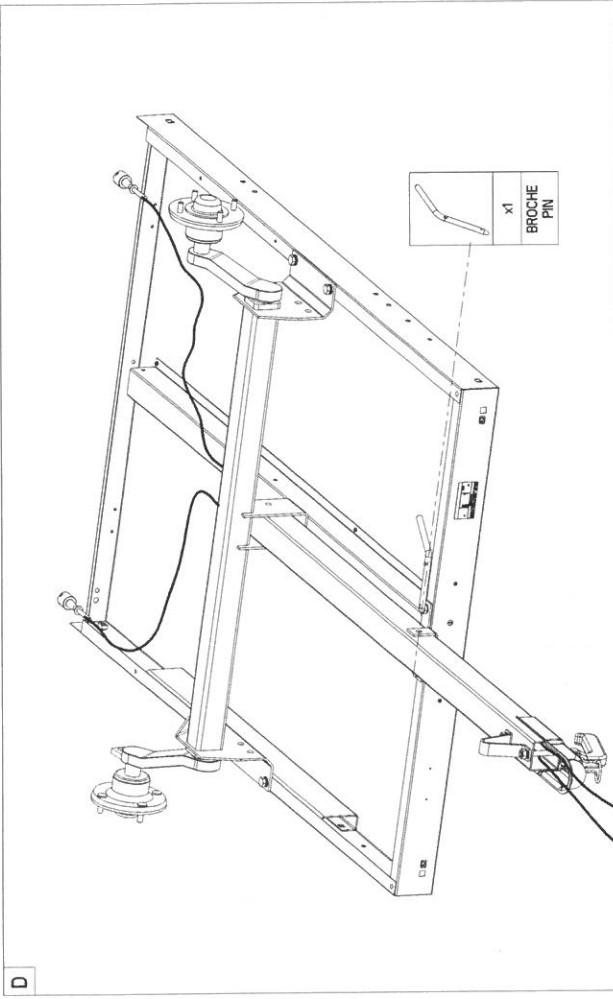

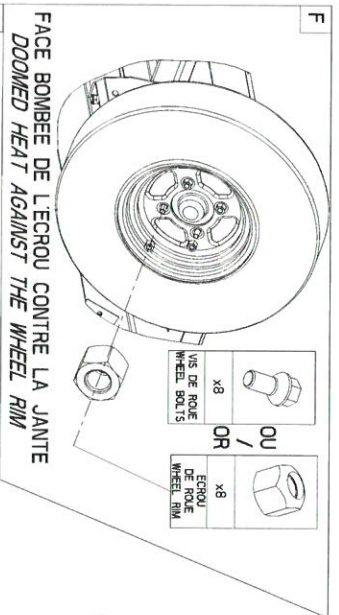

1 RETOURNER LA REMORQUE
TURN OVER THE TRAILER

FACE BOMBÉE DE L'ECROU CONTRE LA JANTE
DOOMED HEAT AGAINST THE WHEEL RIM

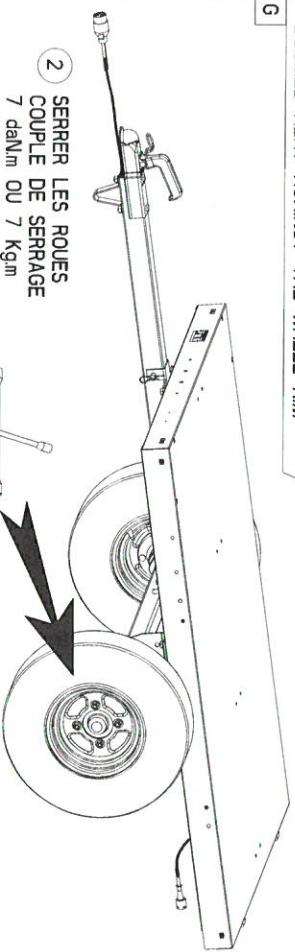

2 SERRER LES ROUES
COUPLE DE SERRAGE
7 daNm OU 7 Kg/m
TIGHTEN THE WHEEL
NUTS TORQUE
7 daNm or 7 Kg/m

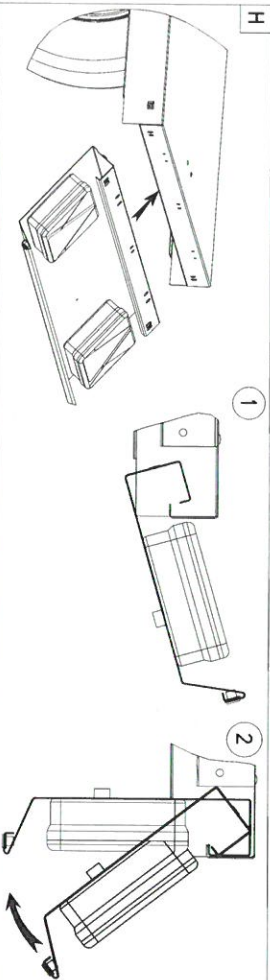

NE PAS BLOUER LES FIXATIONS DES OPERATIONS SUIVANTES
NOT TO BLOCK FIXINGS OF THE FOLLOWING OPERATIONS

